



Cult Collections

terzofoco

terzofoco

INDICE - INDEX

3

L'arte e il design custoditi in mani sapienti

8

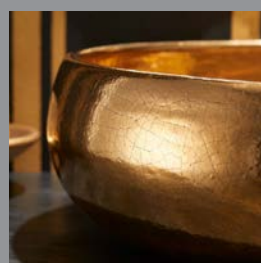

mod. **CIOCCO**

Scheda tecnica mod. CIOCCO

19

20

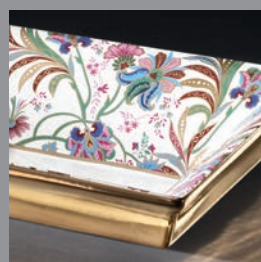

mod. **MANATARES**

Scheda tecnica mod. MANATARES

35

36



mod. **OLD AMERICA**

Scheda tecnica mod. OLD AMERICA

43

44

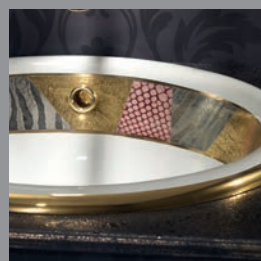

mod. **LUISA**

Scheda tecnica mod. LUISA

53

54



mod. **DALIA**

Scheda tecnica mod. DALIA

75

64



mod. **AMALIA**

Scheda tecnica mod. AMALIA

75

76

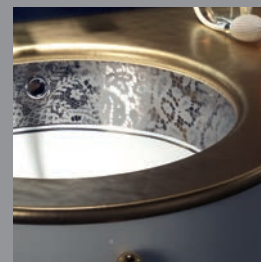

mod. **CLARISSA**

Scheda tecnica mod. CLARISSA

91

92



mod. **BOUQUET**

Scheda tecnica mod. BOUQUET

101

102



mod. **BREGNO**

Scheda tecnica mod. BREGNO

111



L'arte e il design custoditi in mani sapienti

Sulla grande tradizione della maiolica di Deruta, si fonda un'idea fatta al contempo di esperienza e di desiderio di nuove frontiere.

Le mani esperte dei nostri artigiani sanno come coniugare il moderno design con l'aspirazione ad abitare ambienti eleganti e raffinati, in cui lo stile diventa un'abitudine irrinunciabile.

Terzo Foco introduce nella ceramica destinata all'ambiente bagno, la tecnica della terza cottura, per raggiungere livelli qualitativi di altissima artigianalità e dare a ciascuno la possibilità di possedere un pezzo unico come un multiplo d'arte.





Il più tangibile
di tutti i misteri
visibili:
il fuoco

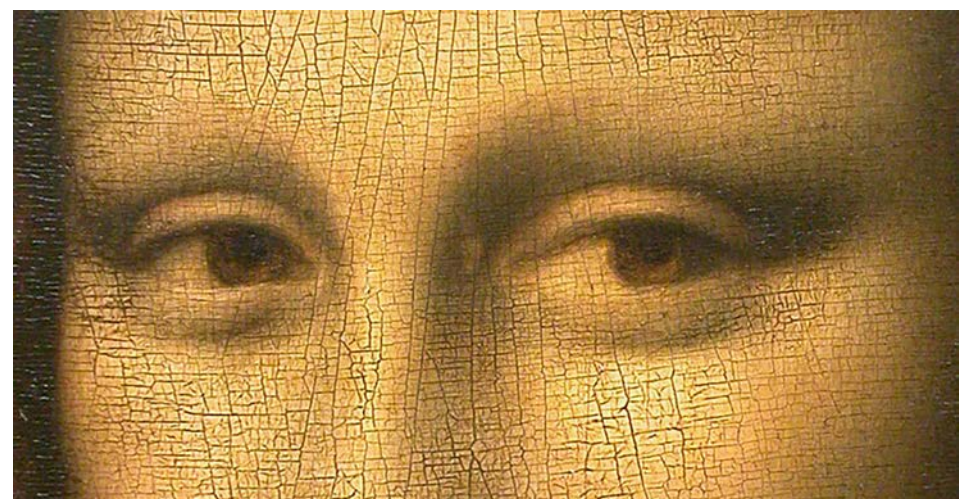

Ispirata all'essenzialità della ceramica Raku, Ciocco è la linea creata per un vero "rinascimento" dell'ambiente bagno.



CIOCCO

CIOCCO



Una linea assolutamente unica dove architetti e designer potranno dare sfogo alla loro creatività giocando su bombature, altezze e diametri. Nella collezione Terzo Foco, l'artigianalità del fornitore si fonde con i design più disparati e le tecniche ceramiche più usate. Un impasto unico prezioso utilizzato per creare oggetti che definire lavabi è riduttivo: il Ceradur.





CIOCCO
FULL GOLD
art. 0302 M43



Amo il lusso.
Esso non giace nella ricchezza e nel fasto
ma nell'assenza della volgarità. La volgarità
è la più brutta parola della nostra lingua.
Rimango in gioco per combatterla.

Coco Chanel

CIOCCO
FULL PLATINUM
art. 0302 M42



CIOCCO
BROWN GOLD
art. 0302 M44





Lavabo in RAKU CLAY di altissima qualità **tornito a mano**. Prodotto in bicottura, prima 1340° per circa 24 ore e poi a 1000°C per altrettanto tempo.

Un tipo d'impasto che si perde nella notte dei tempi quando i maestri giapponesi usavano unire l'arte della forgiatura delle loro spade all'arte ceramista.

L'impasto è molto resistente e duro come l'acciaio di una spada giapponese.

La superficie rimane materica con uno smalto che ricalca i segni del fuoco e che perciò viene definito craquelè.

Washbasin in RAKU CLAY of the highest quality **turned by hand**. Double fired product, first 1340 ° for about 24 hours and then at 1000 ° C for the same time.

A type of dough that is lost in the mists of time when Japanese masters used to combine the art of forging their swords with the ceramic art.

The dough is very resistant and hard like the steel of a Japanese sword.

The surface remains materic with a glaze that follows the signs of fire and is therefore called craquelè.

SCHEDA TECNICA - TECHNICAL SHEET CIOCCO

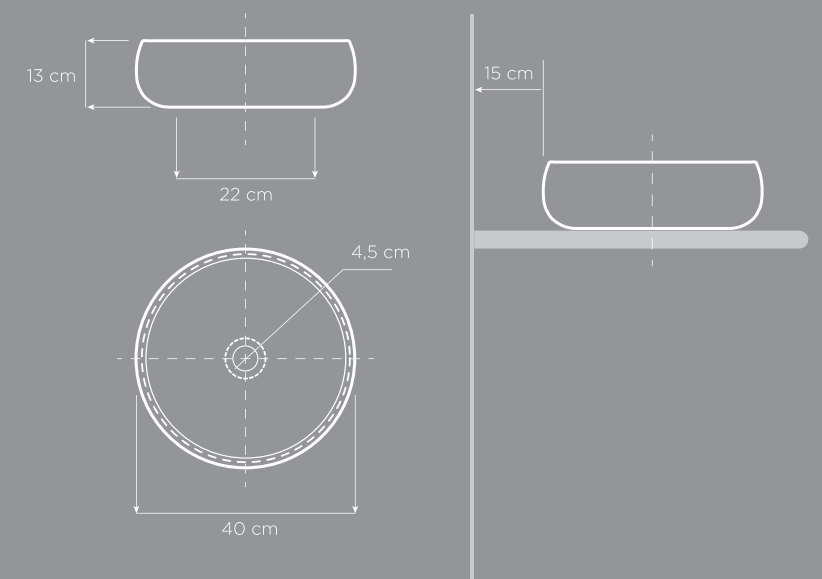

Possibilità di dimensionamento in altezza e larghezza per i lavabi realizzati a mano al tornio.

Possibility of sizing height and width dimension for hand turned washbasins.



MANATARES

La semplice classicità della forma unita alla ricchezza e al pregio di decorazioni, raffinate sia nei colori, sia nell'effetto dei rilievi.





MANATARES
UNDER WOOD



MANATARES
GOLD/RED FLOWER
art. 0403 GRF

La console di ispirazione neoclassica,
rappresenta il completamento ideale
del lavabo Manatares.



Anche la moda diventa fonte di ispirazione per la carica di elegante contemporaneità che può conferire ad ogni bagno.

MANATARES
PLATINUM ROSE BLACK
art. 0403 PRB





MANATARES
PERSIAN GOLD
art. 0403 PG

MANATARES
FIFTH AVENUE PLATINUM
art. 0403 M30 M41

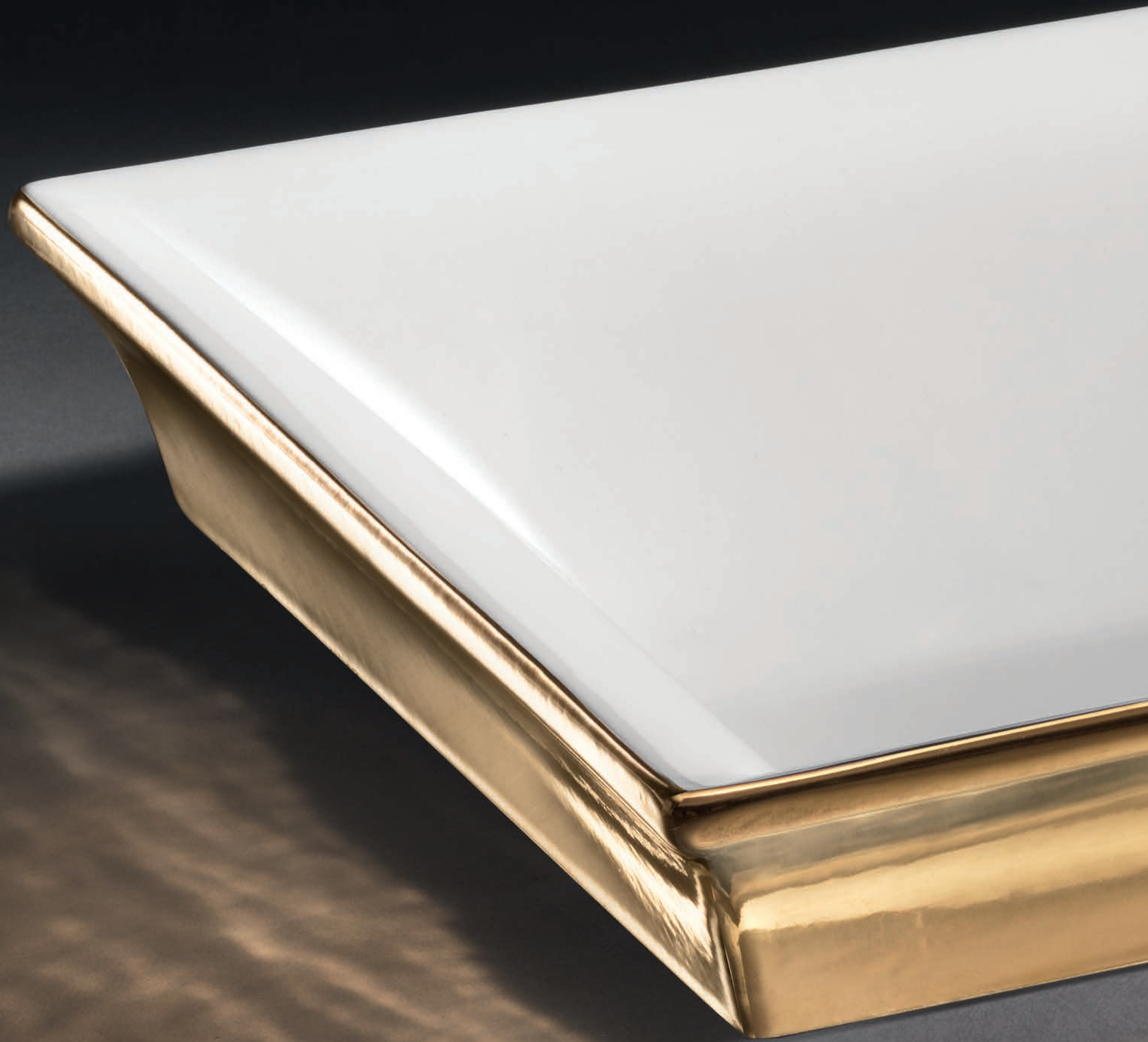

MANATARES
FIFTH AVENUE
art. 0403 M30 M41



MANATARES
GLITTERED GOLD
art. 0403 GG



MANATARES
DAMSI PLATINUM
art. 0403 DP

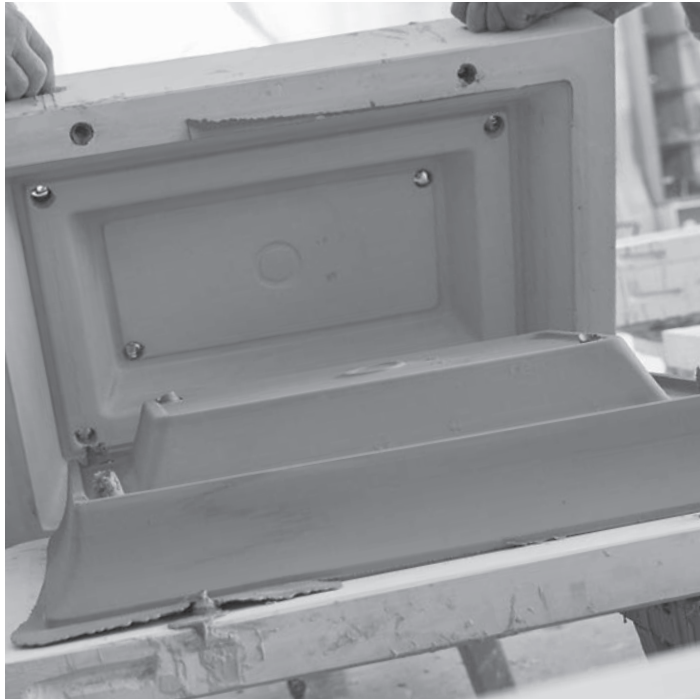

Lavabo in fine fire-clay di primissima qualità COLATO a mano e cotto a 1260° per circa 30 ore.

Il tipo d'impasto unito all'elevata temperatura di cottura ed al ciclo prolungato rende questo prodotto adatto a qualsiasi uso e praticamente **eterno**.

Lo smalto rimane liscio e brillante come una pregiata stoffa orientale.

Washbasin in fine fire-clay of the highest quality, hand-cast and fired at 1260 ° for about 30 hours.

The type of dough combined with the high firing temperature and the long cycle makes this product suitable for any use and practically **eternal**.

The glaze remains smooth and shiny like a precious oriental fabric.

SCHEDA TECNICA - TECHNICAL SHEET MANATARES

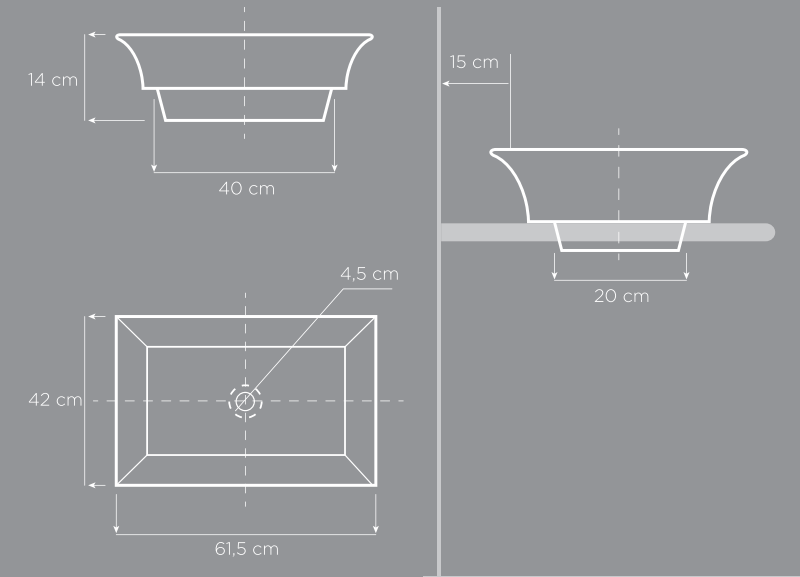



OLD AMERICA

Le suggestioni romantiche di un'epoca avventurosa in questa linea particolarmente rivolta agli amanti dello stile "Shabby chic", con il valore di pezzi unici, dipinti a mano da valenti artigiani che rappresentano la migliore tradizione italiana della ceramica.



Ogni straniero quando pensa all'America, ha in mente lo stesso posto. Non è Manhattan, non è Hollywood, non è neppure il Gran Canyon. Il luogo in cui pensiamo sta in una strada tranquilla dove i vicini si salutano, i cani si annusano senza abbaiare e le luci, la sera, si accendono tutte insieme. Avete presente la casa che nei telefilm separa una scena dall'altra?

Beppe Severgnini

OLD AMERICA
LAVANDA FLOWER
art. 0401 LF



OLD AMERICA
BLUE DELFT
art. 0401 DF



OLD AMERICA
GOLD LINE
art. 0401 GL





Lavabo in fine porcellana francese di primissima qualità **colato a mano** e Cotto a 1260° per circa 30 ore. Il tipo d'impasto molto bianco unito all'elevata temperatura di cottura ed al ciclo prolungato rende questo prodotto adatto a qualsiasi uso e praticamente **eterno**.

Sia la superficie del prodotto che lo smalto rimangono lisci e brillanti come un set di porcellane francesi.

Washbasin in fine French porcelain of the highest quality **hand-cast** and fired at 1260 ° for about 30 hours. The very white type of dough combined with the high firing temperature and the long cycle makes this product suitable for any use and practically **eternal**.

Both the surface of the product and the glaze remain smooth and shiny like a set of French porcelain

SCHEDA TECNICA - TECHNICAL SHEET OLD AMERICA

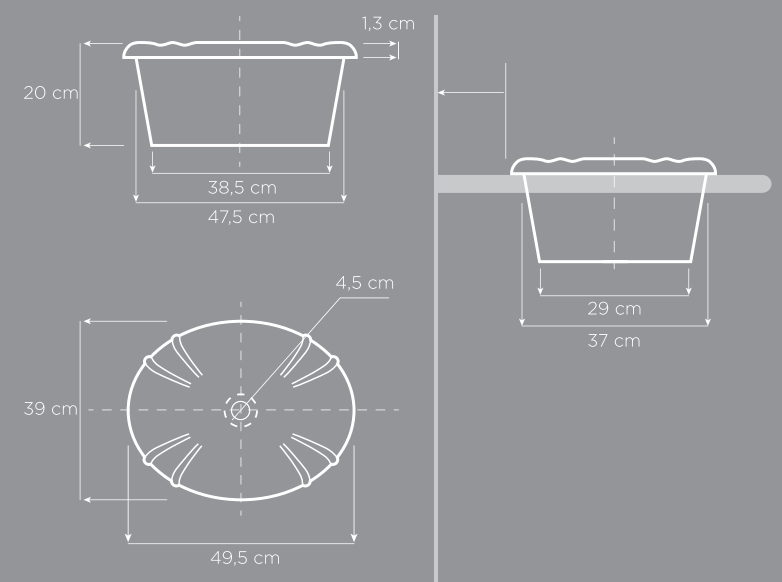



LUISA

L'oro e il rilievo, il lucido e l'opaco in un felice contrappunto di suggestioni decorative per un trionfo del luxury style.



LUISA
GOLD SPIRAL BAND
art. 0423 DX

Colui che ha dell'oro, fa e realizza tutto
ciò che vuole al mondo e alla fine lo usa per
mandare delle anime in paradiso.

Cristoforo Colombo



LUISA
RELIEF DECOR BAND GOLD
art. 0423 NRDG

LUISA
RELIEF DECOR BAND PLATINUM
art. 0423 NRDP



LUISA
PLATINUM DRIPPED BAND
art. 0423 DPE



LUISA
GOLD DRIPPED BAND
art. 0423 OGB



LUISA
BROWN HERALDRY
art. 0423 DO

LUISA
PLATINUM FLOWER BAND
art. 0423 DZ



LUISA
GOLD PINE CONE
art. 0423 DR



Lavabo in fine fire-clay di primissima qualità COLATO a mano e cotto a 1260° per circa 30 ore.

Il tipo d'impasto unito all'elevata temperatura di cottura ed al ciclo prolungato rende questo prodotto adatto a qualsiasi uso e praticamente **eterno**.

Lo smalto rimane liscio e brillante come una pregiata stoffa orientale.

Washbasin in fine fire-clay of the highest quality, hand-cast and fired at 1260 ° for about 30 hours.

The type of dough combined with the high firing temperature and the long cycle makes this product suitable for any use and practically **eternal**.

The glaze remains smooth and shiny like a precious oriental fabric.

SCHEDA TECNICA - TECHNICAL SHEET LUIISA

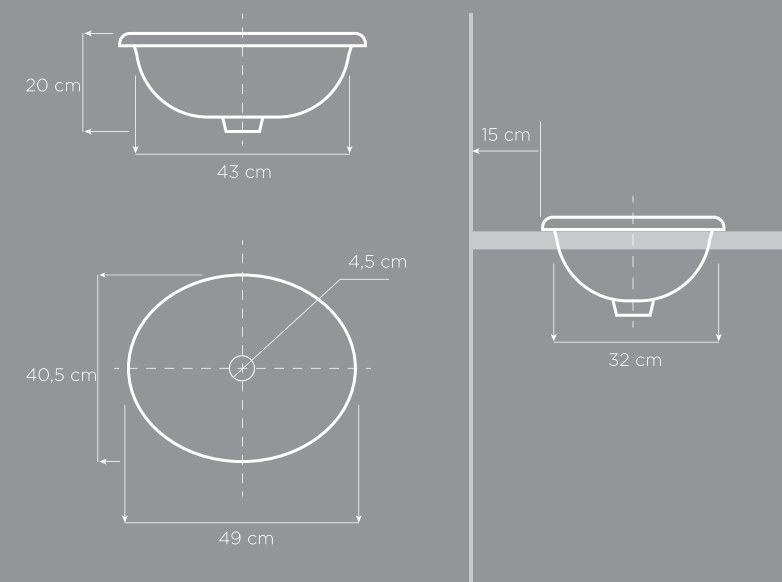

DALIA

Il nome di un fiore per una linea
ispirata al mondo dei fiori.

Una geometria perfetta arricchita da
preziosi decori, per impreziosire il
vostro ambiente bagno.





DALIA
NEW BLUE FLOWER
art. 0429 BNBf

DALIA
BLUE CAPITONÉ
art. 0429 NBC



...Conosco
un'ambiziosa giovinetta,
avida sol di lodi e di piaceri,
cui lo specchio, il balcone e la toeletta son
gravi, importantissimi, pensieri: che neppur
sogna di adornar la mente di pregi che la
rendano piacente:
che neppur sogna di educare il core di virtù
che risvegliano l'amore: contenta di brillar
come una stella,
e di sentirsi sussurrare: è bella!

Da La Dalia.
di Gemma Giovannini

DALIA
GOLD SPIRAL
art. 0429 DX





DALIA
FRUIT BASKET
COBALT BLUE/GOLD
art. 0429 BFCB



Lavabo in fine fire-clay di primissima qualità COLATO a mano e cotto a 1260° per circa 30 ore.

Il tipo d'impasto unito all'elevata temperatura di cottura ed al ciclo prolungato rende questo prodotto adatto a qualsiasi uso e praticamente **eterno**.

Lo smalto rimane liscio e brillante come una pregiata stoffa orientale.

Washbasin in fine fire-clay of the highest quality, hand-cast and fired at 1260 ° for about 30 hours.

The type of dough combined with the high firing temperature and the long cycle makes this product suitable for any use and practically **eternal**.

The glaze remains smooth and shiny like a precious oriental fabric.

SCHEDA TECNICA - TECHNICAL SHEET DALIA

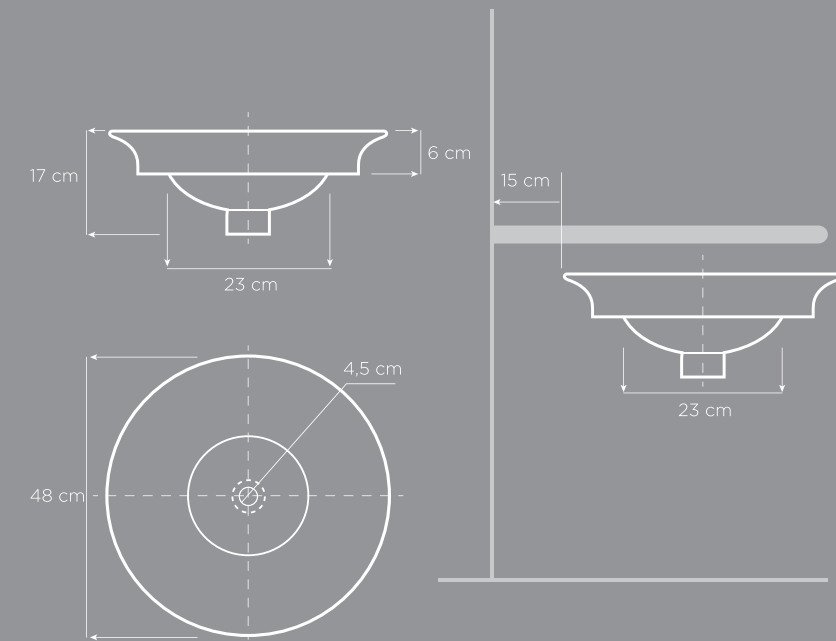



AMALIA

Dalle sapienti mani di artigiane esperte, prende vita il merletto ricamato che viene richiamato nei decori di questa serie, nuovissima nella concezione formale, classica nel suo gusto ricercato.





AMALIA
PLATINUM LACE BAND
art. 0404 PLB

AMALIA
TON SUR TON BIRD
art. 0404 DTSTB



Ogni giorno ella ricamava
seduta davanti al porticato della
sua casa, con accanto uno sgabello su cui
posava un cestinetto di giungo intrecciato
dove riponeva il necessario.
Dalle gugliate di fili abilmente lavorati sboc-
ciavano fiorellini e si formavano volute e
retini.

La ragazza ricamava e soavemente cantava.
Le comari e tutto il vicinato si compiacevano
di quel ricamo lavorato con amore e pazien-
za, infatti bastava uno sguardo per intuirne
la bellezza.

MariGiò



AMALIA
LUXURY RING PLATINUM
art. 0404 M42M43



AMALIA
LUXURY RING MATE
art. 0404 M43M42



AMALIA
CACHEMERE
art. 0404 GC

AMALIA
PERSIAN GOLD
art. 0404 PG



AMALIA
PLATINUM SHADOW
art. 0404 PS





Lavabo in fine fire-clay di primissima qualità COLATO a mano e cotto a 1260° per circa 30 ore.

Il tipo d'impasto unito all'elevata temperatura di cottura ed al ciclo prolungato rende questo prodotto adatto a qualsiasi uso e praticamente **eterno**.

Lo smalto rimane liscio e brillante come una pregiata stoffa orientale.

Washbasin in fine fire-clay of the highest quality, hand-cast and fired at 1260 ° for about 30 hours.

The type of dough combined with the high firing temperature and the long cycle makes this product suitable for any use and practically **eternal**.

The glaze remains smooth and shiny like a precious oriental fabric.

SCHEDA TECNICA - TECHNICAL SHEET AMALIA

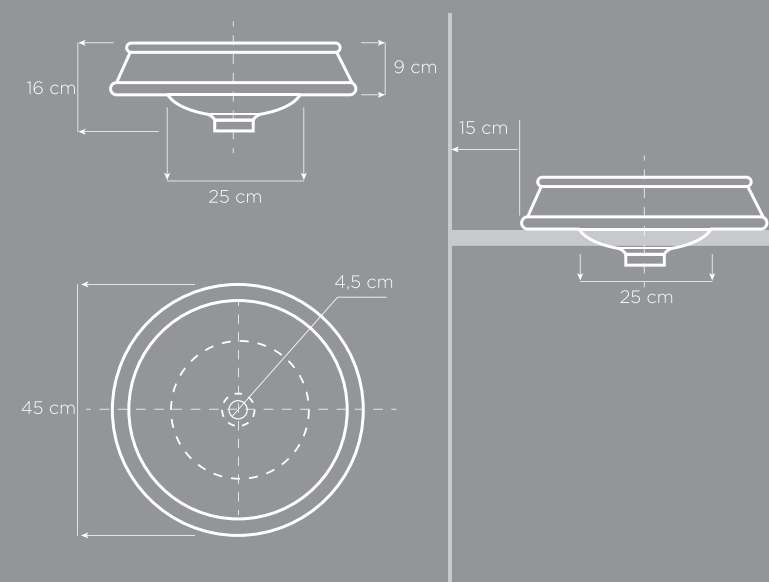

CLARISSA

Il fascino del bassorilievo rinascimentale che fa brillare d'oro l'idea stessa dell'universo, è stata la nostra principale fonte di ispirazione nella creazione di questa linea.



CLARISSA
BAS-RELIEF GOLD BAND
art. 0426 BRGB



CLARISSA
BAS-RELIEF PLATINUM BAND
art. 0426 BRPB



CLARISSA
BAS-RELIEF COPPER BAND
art. 0426 BRCB

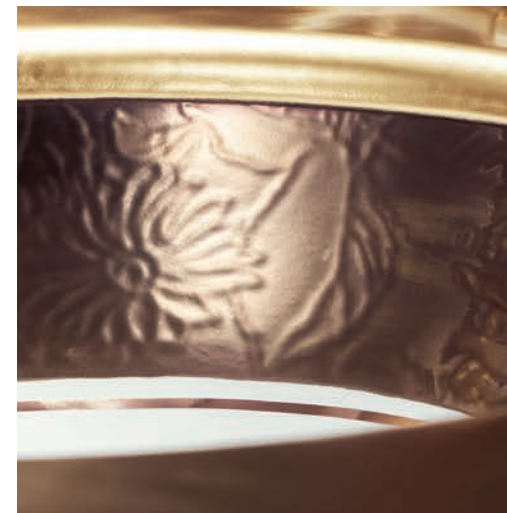

L'umanità può vivere senza la scienza, può vivere senza pane, ma soltanto senza la bellezza non potrebbe più vivere, perché non ci sarebbe più niente da fare al mondo!

Fëdor Dostoevskij

CLARISSA
GOLD BAND
art. 0426 GB



CLARISSA
PLATINUM DRIPPED BAND
art. 0426 DPB



CLARISSA
PLATINUM BAND
art. 0426 PB

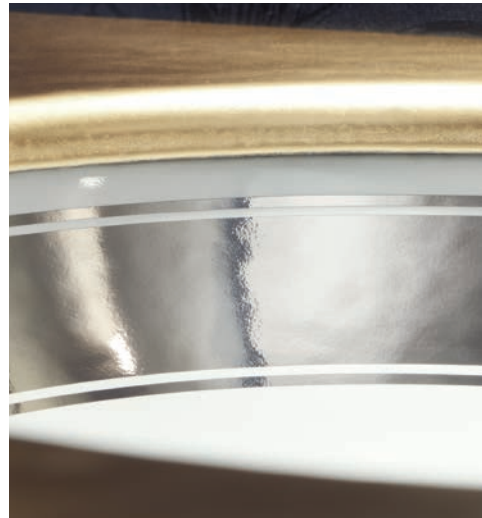

CLARISSA
GOLD DRIPPED BAND
art. 0426 DGB



CLARISSA
HAMMERED COPPER
art. 0426 HC

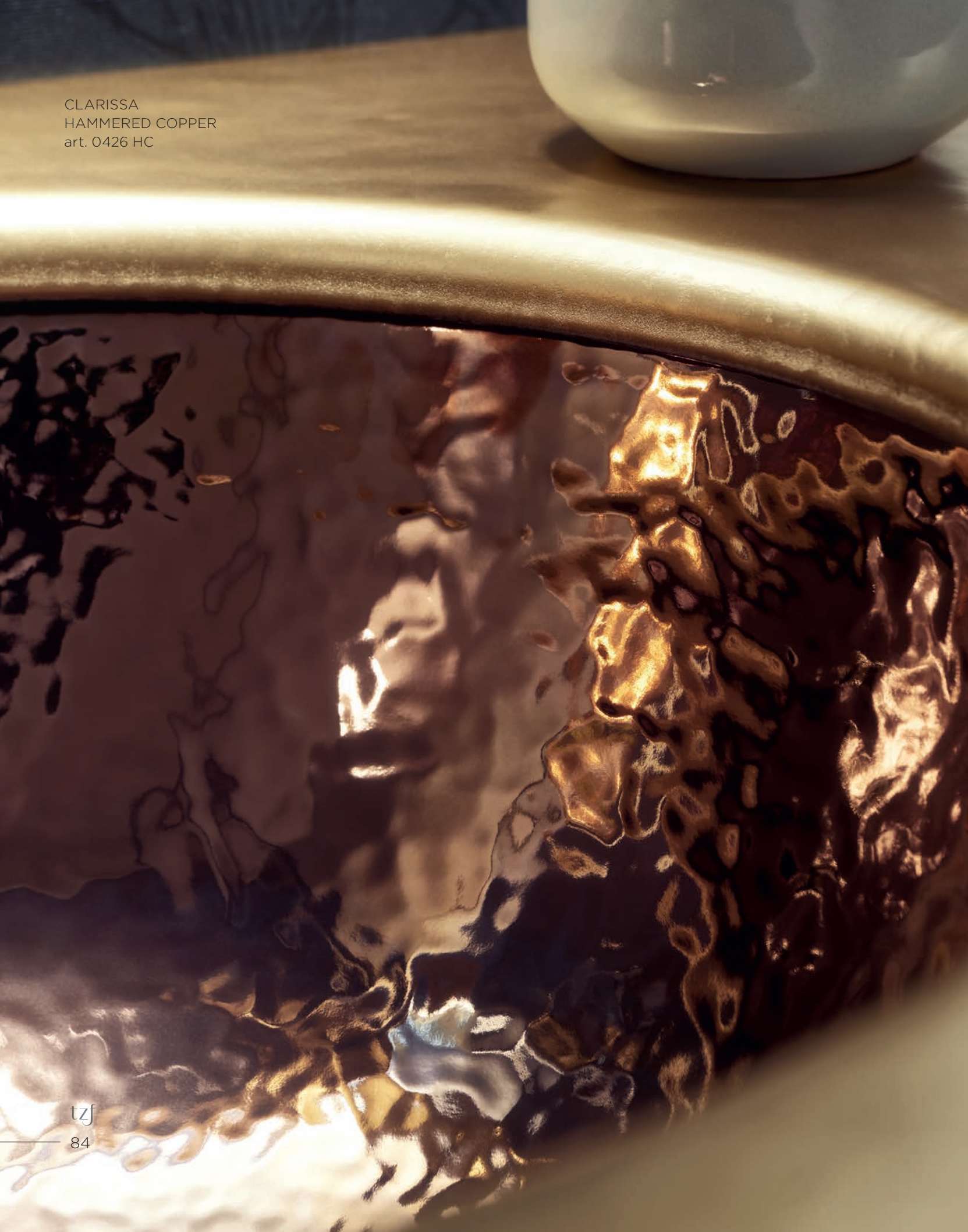

CLARISSA
HAMMERED GOLD
art. 0426 HG



CLARISSA
HAMMERED PLATINUM
art. 0426 HP



CLARISSA
GOLD LACE BAND
art. 0426 GLB

CLARISSA
PLATINUM LACE BAND
art. 0426 PLB





CLARISSA
SAPPHIRE FLOWER
art. 0426 SF



CLARISSA
MARRAKESH
art. 0426 M1



Lavabo in fine fire-clay di primissima qualità COLATO a mano e cotto a 1260° per circa 30 ore.

Il tipo d'impasto unito all'elevata temperatura di cottura ed al ciclo prolungato rende questo prodotto adatto a qualsiasi uso e praticamente **eterno**.

Lo smalto rimane liscio e brillante come una pregiata stoffa orientale.

Washbasin in fine fire-clay of the highest quality, hand-cast and fired at 1260 ° for about 30 hours.

The type of dough combined with the high firing temperature and the long cycle makes this product suitable for any use and practically **eternal**.

The glaze remains smooth and shiny like a precious oriental fabric.

SCHEDA TECNICA - TECHNICAL SHEET
ATHENA CLARISSA
SMALLER VERSION

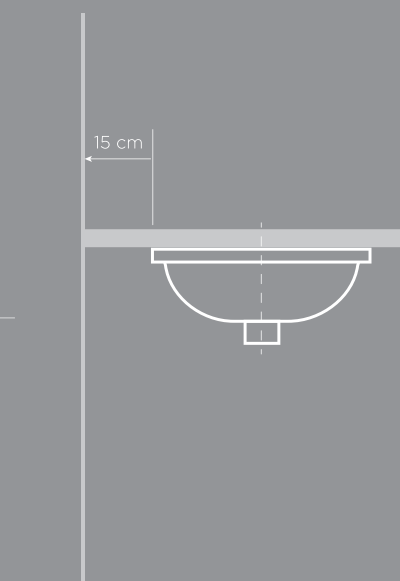
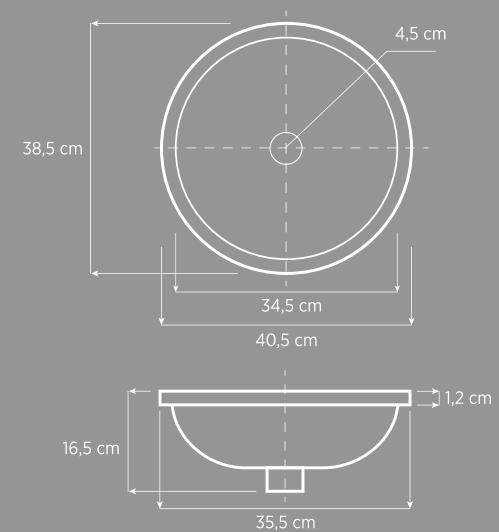
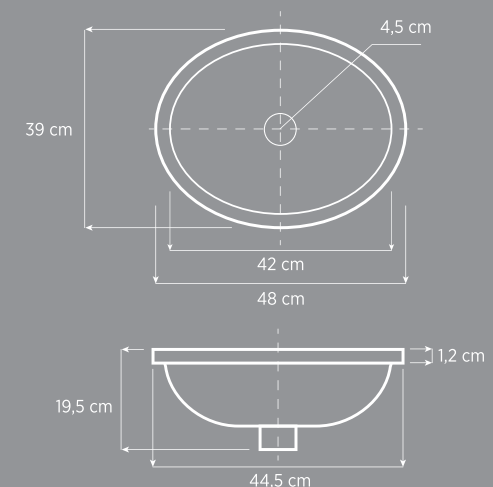
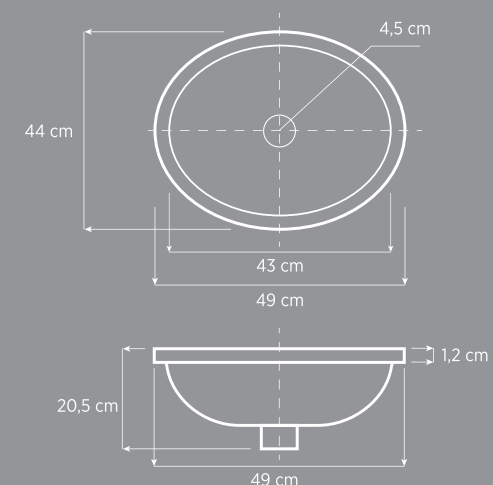



BOUQUET

Ogni petalo di queste rose rimanda alla grande tradizione della porcellana italiana d'arte.

I nostri artigiani compongono ogni dettaglio con amore e pazienza per realizzare quelle che possono essere considerate delle autentiche opere d'arte.



BOUQUET
GLOSSY WHITE
WITH GOLD PETAL
art. 0405 WGP



BOUQUET
GLOSSY WHITE
WITH PLATINUM PETAL
art. 0405 WPP



Un uomo che lavora con le sue mani è un
operaio; un uomo che lavora con le sue mani
e il suo cervello è un artigiano; ma un uomo
che lavora con le sue mani, il suo cervello e il
suo cuore è un artista.

San Francesco d'Assisi



BOUQUET
GLOSSY BLACK
WITH GOLD PETAL
art. 0405 BGP

BOUQUET
GLOSSY WHITE
art. 0405 WW



BOUQUET
GLOSSY WHITE
WITH FULL GOLD PETAL
art. 0405 FGP



BOUQUET
GLOSSY BLACK
art. 0405 BB



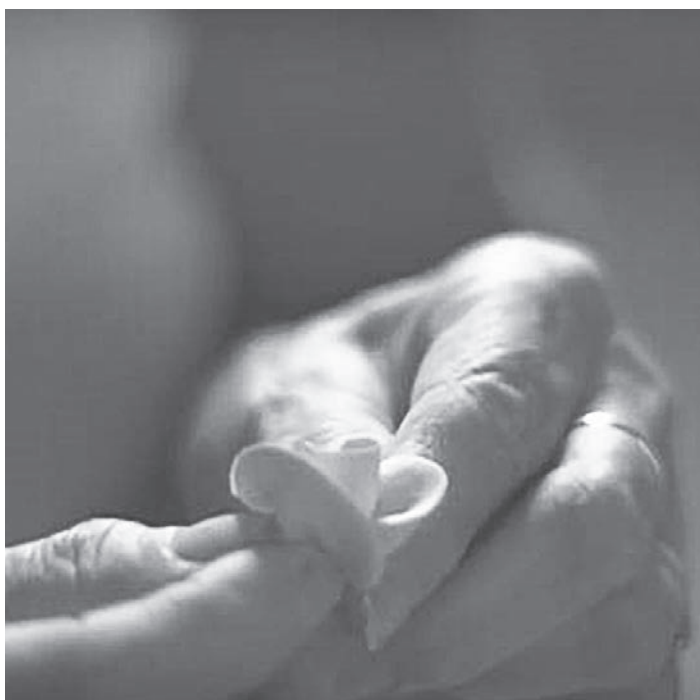

Lavabo in fine porcellana francese di primissima qualità **colato a mano** e Cotto a 1260° per circa 30 ore. Il tipo d'impasto molto bianco unito all'elevata temperatura di cottura ed al ciclo prolungato rende questo prodotto adatto a qualsiasi uso e praticamente **eterno**.

Sia la superficie del prodotto che lo smalto rimangono lisci e brillanti come un set di porcellane francesi.

Washbasin in fine French porcelain of the highest quality **hand-cast** and fired at 1260 ° for about 30 hours. The very white type of dough combined with the high firing temperature and the long cycle makes this product suitable for any use and practically **eternal**.

Both the surface of the product and the glaze remain smooth and shiny like a set of French porcelain

SCHEDA TECNICA - TECHNICAL SHEET BOUQUET

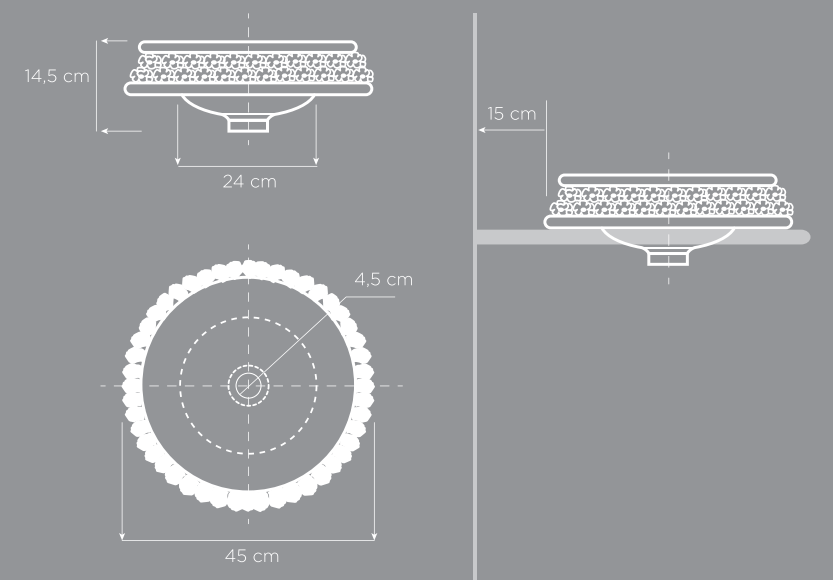



BREGNO

Il design di questa linea contiene l'eco di suggestioni provenzali, di una vita a contatto con la natura e di sensazioni genuine, poetiche, esclusive, come il proprio stile di vita.



BREGNO
DERUTA ARABESQUE
art. 0460 DA



La giusta maniera di fare, lo stile, non è un
concetto vano.
È semplicemente il modo di fare ciò che deve
essere fatto.
Che poi il modo giusto, a cosa compiuta,
risulti anche bello, è un fatto accidentale.

Ernest Hemingway



BREGNO
DERUTA LANDASCAPE
art. 0460 L

BREGNO GOLD
SPIRAL INFLUENCE,
art. 0426GSI



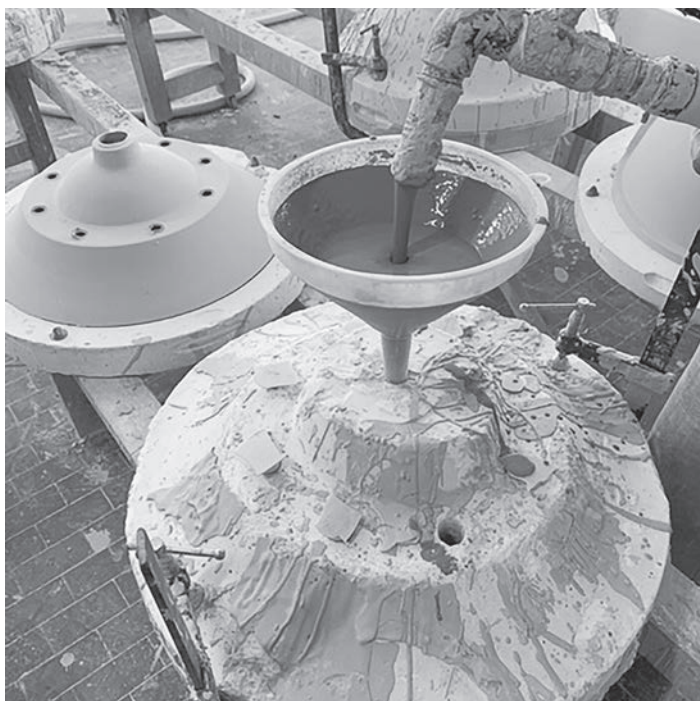

Lavabo in fine fire-clay di primissima qualità COLATO a mano e cotto a 1260° per circa 30 ore.

Il tipo d'impasto unito all'elevata temperatura di cottura ed al ciclo prolungato rende questo prodotto adatto a qualsiasi uso e praticamente **eterno**.

Lo smalto rimane liscio e brillante come una pregiata stoffa orientale.

Washbasin in fine fire-clay of the highest quality, hand-cast and fired at 1260 ° for about 30 hours.

The type of dough combined with the high firing temperature and the long cycle makes this product suitable for any use and practically **eternal**.

The glaze remains smooth and shiny like a precious oriental fabric.

SCHEDA TECNICA - TECHNICAL SHEET BREGNO

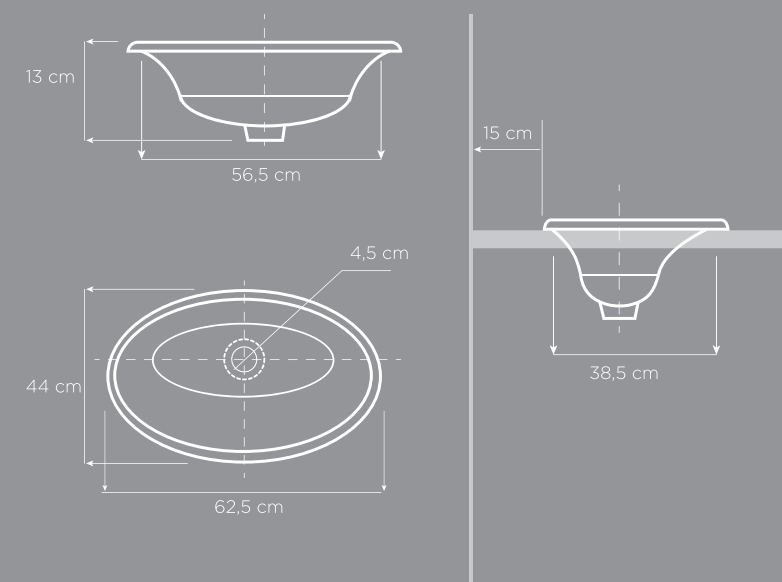

terzofoco



Stile Libero Srl
Via delle Comunicazioni, 20
06135 Perugia - Italy
Tel. +39 075 9710567
Fax +39 075 9001414
www.terzofoco.it
info@terzofoco.it
P.IVA 03499080541



terzofoco.it

terzofoco